

Product information presented here reflects conditions at time of publication. Consult factory regarding discrepancies or inconsistencies.

MAIL TO: P.O. BOX 16347 • Louisville, KY 40256-0347
 SHIPTO: 3649 Cane Run Road • Louisville, KY 40211-1961
 TEL: (502) 778-2731 • 1 (800) 928-PUMP • FAX: (502) 774-3624

Visit our web site:
zoellerpumps.com

COLD CLIMATE SIMPLEX 820 GRINDER SYSTEM

P/N 922-0023 OUTDOOR PREPACKAGED SYSTEM WITH SQUARE GUIDE RAIL

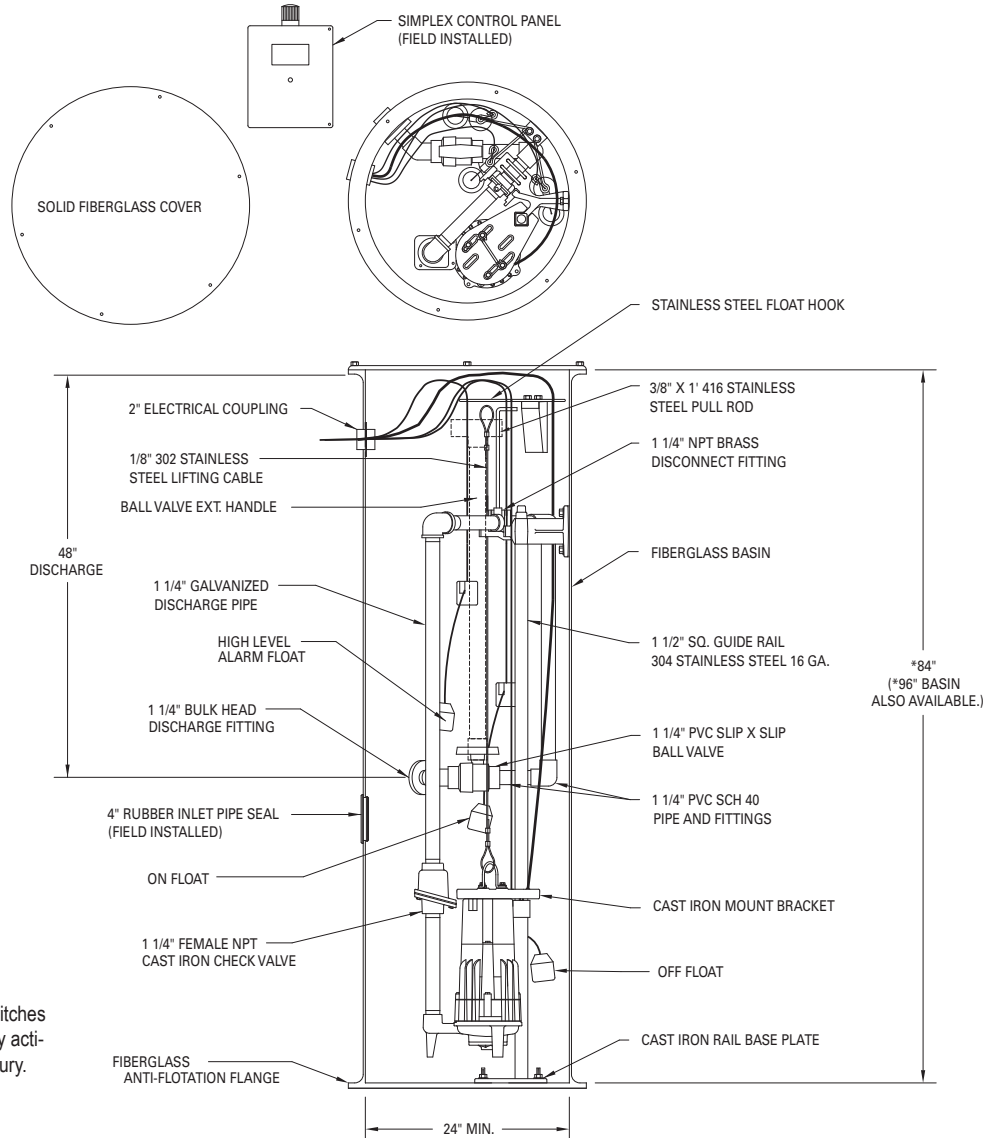

Note: All variable level float switches in this section are mechanically actuated and do not contain mercury.

SK2603

Complete System As Shown Above (P/N 922-0023) Includes:

Qty.	Part No.	Description
1	820-0015	230 Volt, 1 Ph, 2 HP Nonautomatic 820 Grinder Pump with 35' Power Cord
1	10-1037	Simplex Control Panel with Alarm
3	10-1882	35' Variable Level Float Switches with Weights
1	33-0458*	24" X 84" Fiberglass Basin and Cover, Rail System, 8' SS Lifting and 1' Pull Rod

Approximate Weight: 379 lbs.

PROGRESSING CAVITY COLD CLIMATE 810/815 GRINDER SYSTEM

P/N 922-0040 OUTDOOR PREPACKAGED SYSTEM WITH SQUARE GUIDE RAIL

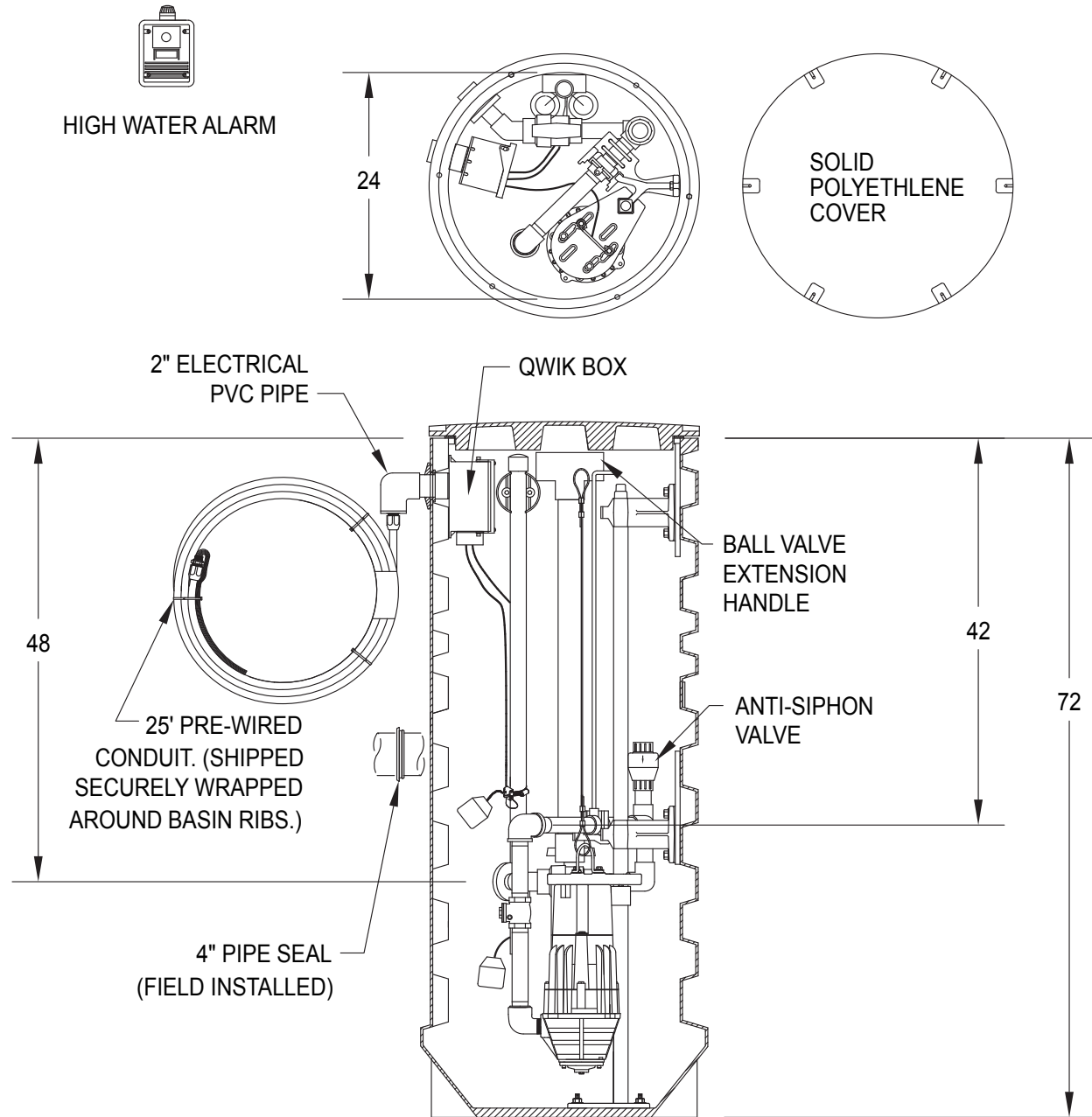

SK2666

Complete System As Shown Above (P/N 922-0040) Includes:

Qty.	Part No.	Description
1	810-0004	230 Volt, 1 Ph, 1 HP Nonautomatic Grinder Pump
1	10-0035	15' Single Piggyback Switch
1	10-0623	Indoor/Outdoor Audible and Visual High Water Alarm
1	33-0579	24" X 72" Cold Climate Poly Ribbed Basin
1	5100-0016	25' Prewired Conduit with Qwik Box

Approximate Weight: 340 lbs.