

Product information presented here reflects conditions at time of publication. Consult factory regarding discrepancies or inconsistencies.



MAIL TO: P.O. BOX 16347 • Louisville, KY 40256-0347  
 SHIP TO: 3649 Cane Run Road • Louisville, KY 40211-1961  
 TEL: (502) 778-2731 • 1 (800) 928-PUMP • FAX: (502) 774-3624

Visit our website:  
 zoellerpumps.com

## Timed Dosing Simplex Pump Control Panel

### Motor Contactor Control Programmable Timed Dosing

Zoeller Pump Company control panels provide residential and commercial customers with a reliable means of controlling a single phase pump in onsite septic installations.

A programmable timer activates a magnetic motor contactor to turn the dosing chamber pump on and off. A high or low water condition will override the timer to turn the pump on or keep the pump from running dry.

An alarm float activates the audio/visual alarm system indicating a high liquid level. Common applications include media filter systems, pressure distribution systems, mound systems, or any application requiring a timed dose.

Note: All variable level float switches for these control panels are mechanically activated and do not contain mercury.



- |   |  |
|---|--|
| <ol style="list-style-type: none"> <li>1. Programmable Timer - with separate variable controls allows for setting the on and off times from .05 seconds to 30 hours</li> <li>2. Rating Label</li> <li>3. Alarm Beacon - large red light provides 360° visual check of alarm condition</li> <li>4. Schematic diagram - (loose in enclosure)</li> <li>5. Circuit Breaker - provides pump disconnect</li> <li>6. Power and Pump Terminal Block - includes terminals for separate pump and control power</li> <li>7. Spare fuse</li> <li>8. Exterior Horn Test/Normal/Silence Switch - allows alarm horn to be silenced and allows alarm system to be tested</li> <li>9. Alarm Horn - provides audio warning of alarm condition</li> <li>10. Pump Specifications Label</li> </ol> | <ol style="list-style-type: none"> <li>11. Tested Stamp</li> <li>12. Timer Instruction Label</li> <li>13. UL Label</li> <li>14. Ground Lug</li> <li>15. Float Switch Terminal Block</li> <li>16. Magnetic Motor Contactor - controls the pump by switching both electrical lines</li> <li>17. Backplate Label - includes diagram of float, pump, and power connections</li> <li>18. HOA Switch - for manual control of the pump</li> <li>19. Alarm Fuse</li> <li>20. Control Fuse</li> </ol> |
|---|--|

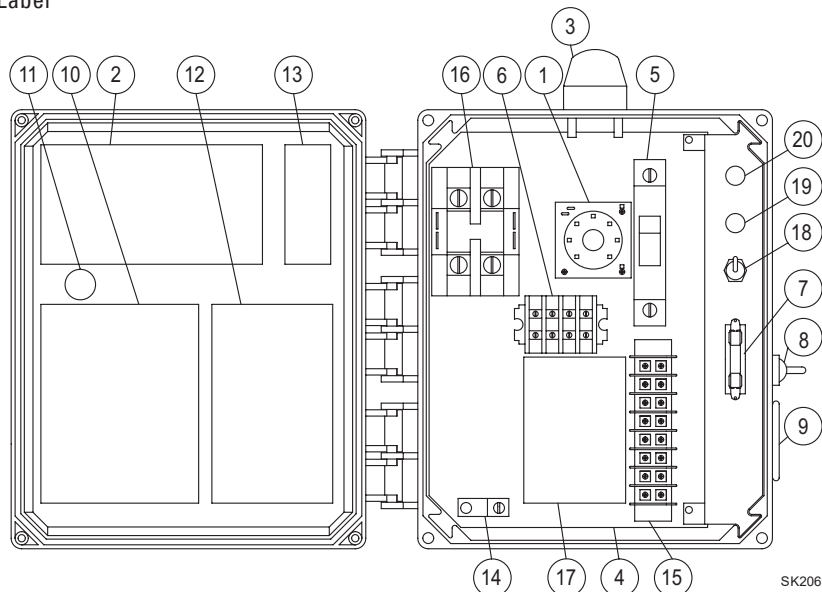

SK2069

## DELUXE MODELS

Part Number	Mode	Voltage	Phase	FLA
10-0684	Simplex	115	1	0 - 20 Amps
10-0697	Simplex	115/200/230	1	0 - 20 Amps
10-1430	Duplex	115/200/230	1	0 - 20 Amps

## SPECIFICATIONS

**Enclosure:** 10" x 8" x 4" (Simplex); 14" x 12" x 6" (Duplex), NEMA 4X, watertight, noncorrodible engineered thermoplastic

**Alarm/Control Section Voltage:** 120 VAC, 60 Hz, single phase, 40 watt maximum (alarm condition)

### Pump Section:

120V models - 120 VAC, 60 Hz, single phase, 0 - 20 FLA

230V models - 230 VAC, 60 Hz, single phase, 0 - 20 FLA

## STANDARD FEATURES

- **UL labeled** - entire control system (panel and switches) meets and/or exceeds industry safety standards
- **Complete Packages** - panels include low level cutout, timer override and high water alarm variable level float switches
- **Installation Instructions** - complete step-by-step instructions allow for easy installation
- **Lockable Latch** - Added security and protection for your system
- **Two-Year Limited Warranty** - our commitment to customer satisfaction
- **Redundant off circuit (redundant off float sold separately)** - protection against primary switch failure
- **Event Counters** - allows monitoring of pump cycles
- **Elapsed Time Meter** - allows monitoring of hours run

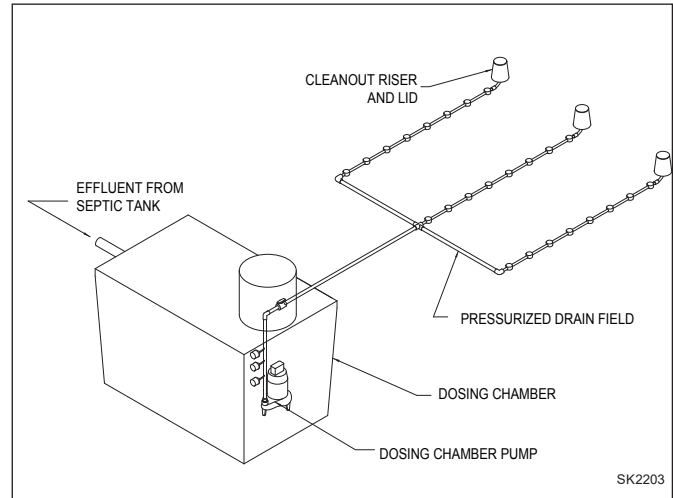

Typical Pressure Distribution System

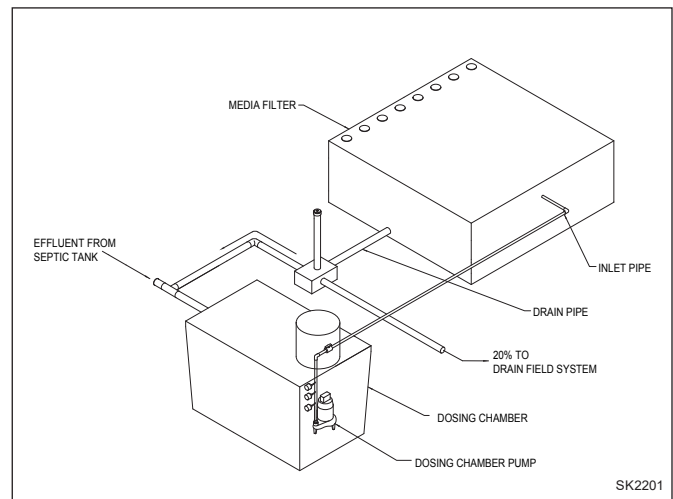

Typical Single Pass or Recirculating Media Filter Systems

## SEQUENCE OF OPERATIONS FOR SIMPLEX TIMED DOSING

1. Operation can begin after the following:
  - Correct voltage is supplied to the panel
  - A good ground is supplied to the panel
  - Pump is connected correctly to the panel
  - Panel circuit breaker is closed
  - Floats are installed properly
  - Pump HOA Switches are set to "Auto"

The control panels are available for use with two, three, or four float combinations.

2. In a two float system, one float in the tank is the *Low Level Cutout* float while the other is a *High Level Alarm* float. The normal operating level should be between the *Low Level Cutout* position and the *High Level Alarm* position.
3. When the *Low Level Cutout* float switch is closed, the pump will be ready to energize. The pump will become operational by using the *On/Off* timer.

4. In the event the liquid level continues to rise, the alarm float switch will be closed. When the alarm float switch is closed, the following will occur:
  - The external high water light will illuminate
  - The audible high water horn will sound
5. The audible high water horn can be silenced by flipping the alarm silence switch. The horn silence relay automatically resets the alarm after the high water condition has been resolved.
6. The three float system adds a *Timer Override* float. The *Timer Override* float gives you the option of pumping from the basin while the timer is in the *Off* cycle. It is only intended for times of abnormally high liquid level intrushes. The normal operating level should be between the *Low Level Cutout* float and the *Timer Override* float.
7. A four float system includes a *Redundant Off* float, a *Low Level Cutout* float, a *Timer Override* float and a *High Level Alarm* float. The *Redundant Off* float is positioned slightly below the *Low Level Cutout* float, but above the pump. The normal operating level should be between the *Low Level Cutout* position and the "Timer Override" position. The *Redundant Off* and the *Low Level Cutout* float switches must be closed for the pump to operate on the timer.

ALL ZOELLER PUMP COMPANY PRODUCTS MUST BE INSTALLED IN ACCORDANCE WITH LOCAL AND/OR STATE PLUMBING AND/OR HEALTH DEPARTMENT CODES.